

717-148
FIRST Special Purpose Reducer Stuffing Adapter
Mates with Series 75 Metal-Core Conduit (750-145 & 750-147)

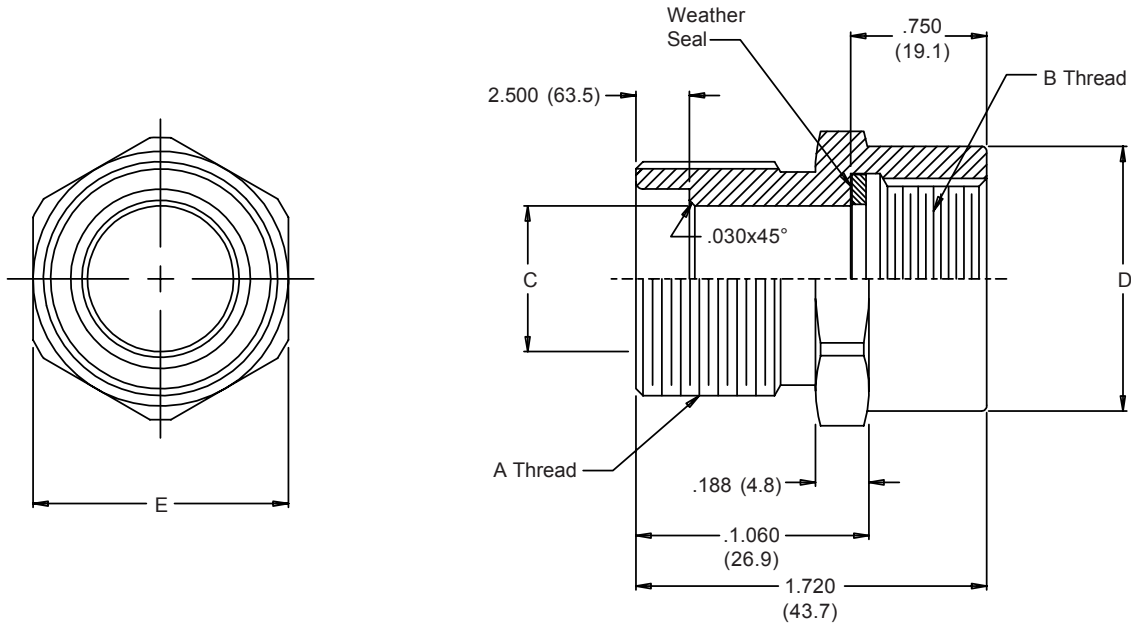

717-148-AB

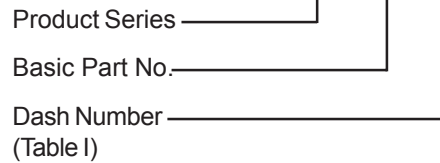

TABLE I

Dash Number	A Thread Class 2A	B Thread Class 2B	C Dia	D Dia	E Hex Flats
AB	7/8-12 UN	1-12 UN	.406 (10.3)	1.130 (28.7)	1.130 (28.7)
CD	1 1/8-12 UNF	1 1/4-12 UN	.640 (16.3)	1.380 (35.1)	1.380 (35.1)
DG	1 1/4-12 UNF	1 1/2-12 UNF	.953 (24.2)	1.630 (41.4)	1.750 (44.5)
BC	1-12 UNF	1 1/8-12 UNF	.515 (13.1)	1.250 (31.8)	1.250 (31.8)
BD	1-12 UNF	1 1/4-12 UNF	.515 (13.1)	1.380 (35.1)	1.380 (35.1)

Metric Dimensions (mm) are indicated in parentheses.